

Technological and structural calculation of the recuperator for air preheating on the cupola furnace

Lazić, Ladislav; Jandrić, Ivan; Pomahač, Marin

Source / Izvornik: **63rd IFC Portoroz 2023 : conference proceedings, 2023**

Conference paper / Rad u zborniku

Publication status / Verzija rada: **Published version / Objavljena verzija rada (izdavačev PDF)**

Permanent link / Trajna poveznica: <https://um.nsk.hr/um:nbn:hr:115:245404>

Rights / Prava: [In copyright](#) / [Zaštićeno autorskim pravom.](#)

Download date / Datum preuzimanja: **2024-07-09**



SVEUČILIŠTE U ZAGREBU
METALURŠKI FAKULTET
UNIVERSITY OF ZAGREB
FACULTY OF METALLURGY

Repository / Repozitorij:

[Repository of Faculty of Metallurgy University of Zagreb - Repository of Faculty of Metallurgy University of Zagreb](#)



TECHNOLOGICAL AND STRUCTURAL CALCULATION OF THE RECUPERATOR FOR AIR PREHEATING ON THE CUPOLA FURNACE

Summary

In cases of melt preparation for larger tonnage production, the most common melting method used in iron casting plants is the cupola furnace. The main advantages of cupola furnaces compared to electric ones are: less sensitive to low quality charge materials and contaminants, oxidation and reduction reactions take place within and above the melt zone during cupola melting, which allows the use of highly oxidized and low quality scrap material, lower prices of alloys and non-metallic additions. The metallurgical process in the cupola furnace can be intensified by preheating the air that is blown into the working space of the furnace through nozzles. In addition to increasing aggregate productivity, reduced coke consumption and higher melt temperatures are also achieved. For this purpose, tubular recuperators are usually used, which exploit the enthalpy of the output cupola gases, and in some cases also the enthalpy of natural gas combustion gases. For the cupola furnace with a capacity of 3 t/h, the technological and construction calculation of the recuperator sections was carried out. The calculation is based on the experimental data of furnaces and recuperators that are used in practice. It consists of the calculation of the combustion of natural and cupola gases and the calculation of the construction of three recuperator sections. In the first section, which is connected to the nozzles, i.e. in the zone of the highest temperatures of the combustion gases, the final heating of the air is achieved before entering the cupola furnace, in the second section the cupola gases are reheated before its combustion, while in the third section the air is heated from the initial ambient temperature. The design of the tubular heat exchanger with counter-flow of flue gases and air, composed of steel U-tubes, was adopted.

Keywords: cupola furnace, air preheating, recuperator

INTRODUCTION

The cupola furnace is a vertical shaft furnace used primarily for melting cast iron. It is similar in principle (except in scale) to the blast furnace used for chemically reducing metal oxides in the production of iron, zinc and lead. Typically, cupola melting is used in large tonnage foundries. In fact, 60% of iron casting tonnage is melted in a cupola. The cupola is ideal for melting cast iron because the molten droplets of metal directly contact the coke and flux during their descent, saturating the liquid iron with carbon and refining the metal product. This structure allows the cupola to melt nearly almost all ferrous scrap. The energy efficiency of cupola melting ranges from 40 to over 70% [1,2].

Although the concept of cupola melting has not changed in recent years, best practices include many new technologies to improve energy efficiency and productivity. The potential areas of improvement in cupola melting are as follows [1]:

- Refractories - The aggressive melting conditions in modern cupolas has resulted in the development of new cement castables and spray monolithic linings (requiring no forms)

which provide superior properties in terms of wear, heat transfer, and ease of installation and repair [3];

- Oxygen Enrichment of Blast - Plants using oxygen enrichment typically add oxygen at volumetric flow rates of 2 to 20% of the blast air to increase the temperature and the melt rate. Oxygen is usually introduced at the tuyere level of the cupola;
- Supplemental Energy - Although coke is the main source of energy for cupola melting, the use of supplemental energy is a promising way for improving energy and operational efficiency of cupola melting. Oxygen-fuel burners with dust injection systems provide a method of recycling plant-generated residues (cupola dust, finishing dust, and sand reclamation dust) while increasing the cupola volume for melting, leading to better energy efficiency [4];
- Intelligent Control - The harsh interior of the cupola has made it difficult to introduce the sensors required to measure and control process variables. Therefore, many cupolas are operated in open-loop mode. Recently, computer models have become available, including neural network models, to provide rapid estimates of process variables for use in automated control schemes. Computer control of the cupola process lowers material and processing costs, reduces scrap and improves quality;
- Plasma-Fired Cupol - A plasma torch is installed in the tuyere zone of the cupola where blast air is supplied and mixed with the plasma torch flow in a special mixing chamber. This arrangement is reported to increase productivity (up to 60%) from decoupling of the combustion process and total heat input to the cupola;
- Cokeless Cupola - Iron is melted in this cupola using fuels such as natural gas, propane, diesel oil or pulverized coal in place of coke. Elimination of coke decreases the CO content in the waste gas to 1%, indicating more efficient energy use when compared with the 12 to 20% CO emission typical in a conventional cupola. Use of cokeless cupolas simplifies the emission control system and results in lower sulfur content in metal and reduced slag production;
- Preheating Systems - The high-temperature off-gas from the melting furnace can be used to preheat scrap for the second charge of the heat or the first charge of the next heat. Scrap preheating has proven to reduce the energy for melting (by up to 50-75 kWh per ton).
- Air Blast Preheating - Hot blast operations offer several advantages like energy savings, lower sulfur pick-up, and higher carbon pick-up. However, these benefits are substantially reduced if the blast air temperature is below 400°C. Therefore, secondary gas/oil firing is often used to supplement recuperative waste gas systems to produce high-temperature blast air consistently. Some new cupola installations with efficient off-gas combustion systems (which utilize the energy associated with CO emissions) and waste heat recuperators preheat the hot blast air up to 650°C [5].

For the given production capacity of the cupola furnace of 3 t/h, the design calculation of the basic dimensions of the furnace was carried out in the paper [5]. The following dimensions were determined: useful height of the furnace, well zone, inner and outer diameter of the furnace (Figure 1). In this work, we decided to apply the Air Blast Preheating method in order to achieve the above-mentioned benefits. With the aim of reaching the temperature of the hot blast air up to 650° and using the energy associated with CO emission in the waste gases. In order to reach the temperature of the hot blast air up to 650° and to use the energy associated with CO emission

in

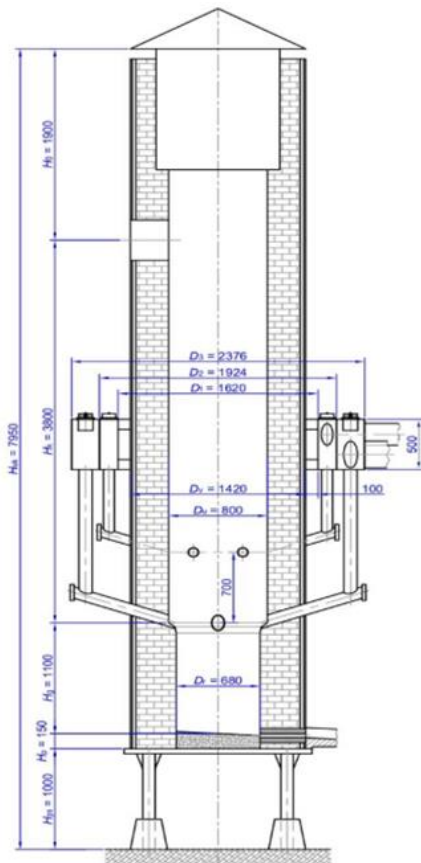

Figure 1. Dimensions of the cupola

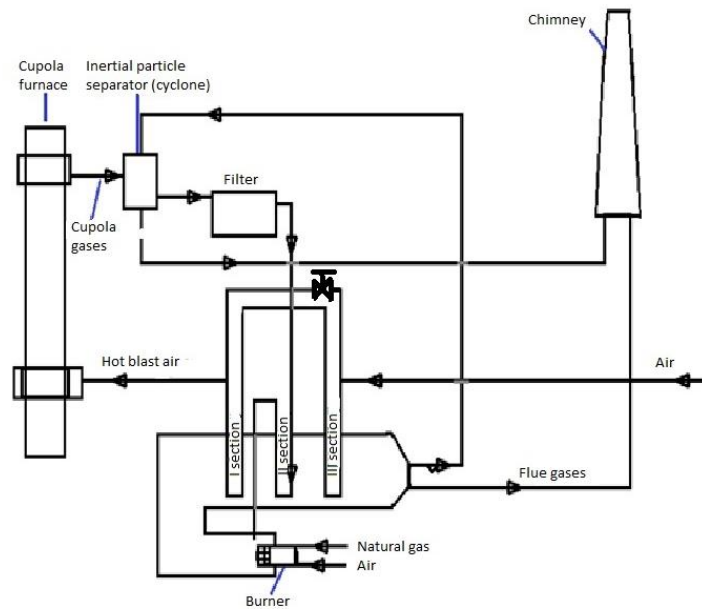

Figure 2. Schematic representation of recuperator sections for air preheating and cupola gases

the waste gases, the following waste gas recovery system was adopted (Figure 2). Such an arrangement of recuperators with a design calculation is presented in Ref. 6. Heat recuperators recover heat from the exhaust gases and heat the incoming combustion air. A convective recuperator is a type of recuperator that circulates hot gases through several small-diameter pipes contained within the flue duct. The cooler gases pass over the pipes and absorb much of their heat. It is planned to install a heat exchanger with counter-current flow with a triangular pitch of the tube arrangement. Atmospheric air enters the first section and, previously heated to 140°C , enters the third section to reach a temperature of 600°C at the exit. After purification, the dome gases enter the first section with a temperature of 625°C , and heated to 800°C , they are led to the zone of the flame created by the combustion of natural gas in order to fully use the energy associated with CO emission. The basic parameters for the calculation of the recuperator sections are shown in Table 1. The data are determined according to the material balances of real cupola furnaces [7].

The construction calculation of individual sections of the recuperator consists of several steps:

- Calculation of the combustion of natural gas and cupola gases with the excess air of 10%;
- Calculation of the composition of the mixture resulting from the combustion of natural and cupola gases;
- Calculation of heat transfer by convection and radiation;
- Calculation of the heating surface and dimensioning of the recuperators.

Table 1. Basic parameters for calculation of recuperator sections

	Measuring unit	I Section	II Section	III Section
Mass flow of air	m^3/h	2500		
Mass flow of cupola gases	m^3/h	2840		
Outlet temperature of preheated air	$^{\circ}C$	600	450	350
Inlet air temperature	$^{\circ}C$	350	140	0
Flue gas temperature in front of each section	$^{\circ}C$	800	625	424

CALCULATION OF THE DIMENSIONS OF THE RECUPERATORS

a) Calculation of the combustion of natural gas and cupola gases with the excess air of 10%

Table 2. Composition of natural gas

CH ₄	C ₂ H ₄	C ₂ H ₆	C ₃ H ₈	C ₄ H ₁₀	N ₂	CO ₂	H ₂ O
94.64	0.08	2.383	0.257	0.109	1.345	0.069	1.12

Table 3. Composition of cupola gases

CO	O ₂	N ₂	CO ₂	H ₂ O
13.843	11.866	0.396	72.776	1.12

Table 4. Composition of natural gas combustion products

CO ₂	H ₂ O	N ₂	O ₂
7.552	14.924	62.449	1.506

Table 5. Composition of cupola gases combustion products

CO ₂	H ₂ O	N ₂	O ₂
13.3	1.033	85.793	0.452

b) Calculation of the composition of the mixture resulting from the combustion of natural and cupola gases

The following shares of natural gas and dome gas are adopted: $n_{n.g.} = 0.349$ and $n_{c.g.} = 0.651$. It turns out that the CO₂ content in the combustion gases is 11.29%, and H₂O is 5.88%. Knowledge of these shares is essential when determining the heat transfer coefficient by radiation.

c) Calculation of heat transfer by convection and radiation

Table 6. Values of the heat transfer coefficient by radiation by sections

I section	II section	III section
85.06 W/ (m ² ·K)	45.93 W/ (m ² ·K)	18.18 W/ (m ² ·K)

Table 7. Values of the convection heat transfer coefficient by sections

I section	II section	III section
68.9 W/ (m ² ·K)	59.05 W/ (m ² ·K)	57.14 W/ (m ² ·K)

Table 8. Values of the total heat transfer coefficient by sections

I section	II section	III section
153.96 W/ (m ² ·K)	104.98 W/ (m ² ·K)	75.16 W/ (m ² ·K)

d) Calculation of the heating surface and dimensioning of the recuperators

For the adopted inner and outer diameter of the pipe 62/70 mm, Table 9 shows the required heating surface and pipe length by sections. The distances between pipes S_1 (in the same row) and S_2 (between the two rows) are shown in the same table.

	I section	II section	III section
Heating surface, m ²	41.01	63.8	125.7
Pipe length, m	210.3	327.2	644.6
S_1 , m	0.1778	0.1455	0.1455
S_2 , m	0.0889	0.0727	0.0727

A schematic view of the arrangement and position of the pipes is given in Figure 3.

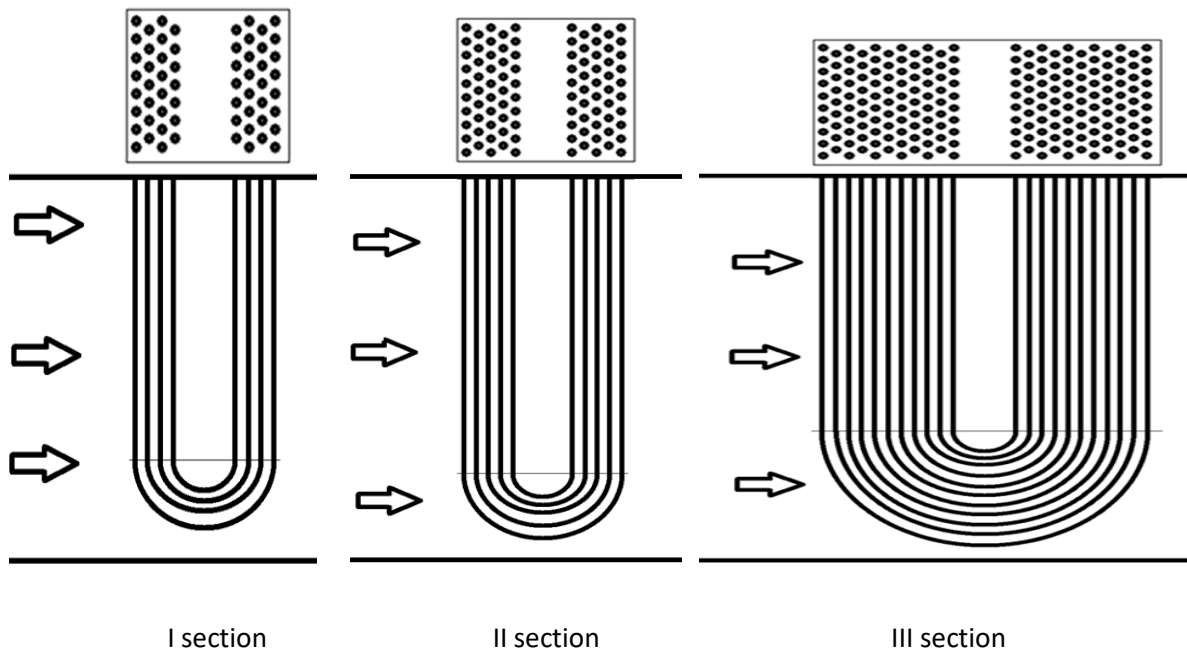

Figure 3. Scheme of arrangement and position of pipes by sections by sections

CONCLUSION

In the introduction of the paper, the most frequently applied new technologies on cupola furnaces to improve energy efficiency and productivity are listed. However, when the investment cost of applying a particular method is compared with the benefits of the same method on existing furnaces, it follows that the application of the Air Blast Preheating method has a number of advantages. For this reason, for the given production capacity of the cupola furnace of 3 t/h, a recuperative waste gas system was proposed, which consists of three sections of convective recuperators, and with which the blast air temperature up to 600°C is achieved.

Using a hot blast produces a shorter and hotter combustion zone, which enables the following advantages:

- a reduction in coke consumption;
- increased C pick up in the iron;
- lower sulfur pick-up;
- reduction in Si loss and
- increased metal temperature.

The thermal efficiency is ~ 40% if the thermal energy is not recovered from the waste gases. Approximately 50% of this energy can be recovered when the thermal efficiency approaches 60%. However, it is the secondary advantages that are important in terms of melting economies. These include the ability to use any available ferrous raw material for all types of iron, in particular, the use of scrap instead of pig iron, and the ability to use liningless cupolas with external pressure systems for long campaigns [8].

REFERENCES

- [1] Advanced Melting Technologies: Energy Saving Concepts and Opportunities for the Metal Casting Industry, 2005, pp. 10-13, http://www.moderneq.com/pdf/Advanced_Melting_Technologies_page_8.pdf
- [2] Kamlesh, R. et al, "Energy-Efficient Melting Technologies in Foundry Industry", Indian Foundry Journal, Vol. 62, No. 9 (2016), pp. 41-42
- [3] Harbin, H.P., Reno Jr., E.S., New Ideas for Cupola Refractory Practice, AFS Trans. 98, p. 529-531
- [4] Niehoff, T.B., Smith, S.P., Saha, D., Cupola Operating System for Dust Injection and Improved Process Flexibility, AFS Tran. 1998, p. 427-433.
- [5] Lazić, Ladislav; Lovrenić-Jugović, Martina; Borošić, Matija, Determining the ratio of the metal components of the charge at the cupola furnace, Conference Proceedings 62nd IFC Portoroz 2022, Ljubljana: Slovenian Foundrymen Society, 2022.
- [6] Matyuhin, V.I., Matyuhin, A.V., Calculation and design of a cupola complex for iron smelting, Tutorial, Ural Federal University, 2015, pp. 226 - 232 (in Russian), ISBN 978-5-9904848-2-5
- [7] Svinolobov, N.P., Brovkin, V.L., Furnaces of ferrous metallurgy, Dnipropetrovsk "Porogi", 2004, pp. 69, (in Russian),UDK 669.041/046, ISBN 966-525-443-X
- [8] Cast iron technology. 1. Cast-iron—Metallurgy I. Title 669M413 TN710 ISBN 0-408-01512-8 <https://businessdocbox.com/Metals/69928097-Cast-iron-technology-roy-elliott-bsc-phd-lecturer-department-of-metallurgy-and-materials-science-university-of-manchester-england.html>